

# PX25 1185X555

## SCALE PALLET TRUCK



### PX25

The PX25 pallet truck is a simple, economical and robust tool to be used for lifting and weighing of transported loads. Thanks to the 4 load cells it is able to be very precise and functional in all internal weighing operations; ideal for checking incoming goods, avoiding overloads and determining shipping weights.



### DISPLAY

Its large-sized 6 digits LCD display provides accurate and precise weighing in kg and lb.

The setting of tare shows both gross and net weights.

Weights are shown in 0.5/1 kg/lb steps with 0,05% precision. Tare/Unbalanced load/ Auto-off are the main functions.



## FRAME STRUCTURE

The structure is designed with a double frame consisting of a lower fork on which stands a counter fork. Both forks house two load cells allowing a uniform load distribution, and keeping high weighing accuracy even in case of collision and unbalanced load.



## BATTERIES

The PX25 electronic is powered by 4 x AA standard battery to be fitted in a specific module. The battery provides 30 hours autonomy. The display include a low status indicator



## HYDRAULIC UNIT

Resistant and reliable one piece cast iron pump, worked with numerical control machine, including:

- Maximum pressure valve: safety device that ensures the transpallet against overloads. When the pressure inside the hydraulic circuit exceeds the set calibration value according to the maximum nominal flow, the valve automatically locks the forks.
- ON/OFF lowering valve
- External oil tank



## CONFIGURATION PX25

**STANDARD:** nylon - polyurethane steering wheels and polyurethane tandem rollers



## Descriere

1.1 Producător			LIFTER
1.3 Comandă			Manual
1.4 Poziție operare			Pedestru
1.5 Capacitate maximă	Q	Kg	2500
1.6 Distanța la centrul de aplicare al sarcinii	c	mm	600
1.8 Sarcina de la osie la capătul furcilor	x	mm	975
1.9 Ampatament	y	mm	1250

## Greutăți

2.1 Greutate de operare (acumulator inclus)		Kg	113
2.2 Sarcină osie, încărcare pe spate		Kg	1830
2.2 Sarcină osie, încărcare pe față		Kg	783
2.3 Sarcină osie, liber față		Kg	71
2.3 Sarcină osie, liber spate		Kg	42

## Cauciucuri/Șasiuri

3.1 Cauciucuri: roți direcție			POLY.I./ NYLON
3.1 Cauciucuri: transportoare cu role			POLY.I.
3.2 Mărime cauciuc: roți direcție - Lățime		mm	55
3.2 Mărime cauciuc: roți direcție - Diametru		mm	200
3.3 Mărime cauciuc: transportoare cu role - Diametru		mm	82
3.3 Mărime cauciuc: transportoare cu role - Lățime		mm	60
3.5 Dimensiune cauciuc: roți spate		nr	4
3.5 Dimensiune cauciuc: roți fata		nr	2
3.5 Ax de echilibru spate			No
3.6 Ecartament, față	b10	mm	155
3.7 Ecartament, spate	b11	mm	375

## Dimensiuni

4.4 Înălțime stivuitor	h3	mm	115
4.9 Înălțime manetă în poziția de deplasare, max	h14	mm	1160
4.9 Height of tiller in drive position min	h14	mm	690
4.15 Înălțime, coborât	h13	mm	90
4.19 Lungime globală	l1	mm	1596
4.20 Distanța până la suprafața frontală a furcilor	l2	mm	411
4.21 Lățime globală	b1	mm	555
4.22 Dimensiuni furcă - grosime	s	mm	60
4.22 Dimensiuni furcă - Lățime	e	mm	180
4.22 Dimensiuni furcă - Lungime	l	mm	1185
4.25 Distanța între furci	b5	mm	555
4.32 Gardă la sol și mijloc ampatament	m2	mm	30
4.34 Lățime culoar	Ast	mm	1851
4.35 Rază de virare	Wa	mm	1426

## Performante

5.2 Viteză de ridicare, încărcat	strokes		13
5.2 Viteză de ridicare, descărcat	strokes		13

**Cântar**

Cifre	Q.ty	6
Dimensiune cifră	mm	25
Kilograme		Yes
Livre		Yes
Greutate proprie		Yes
Oprire automata		Yes
Totalizare		No
Numărare		No
Timp de funcționare	h	30
Precizie	%	0.05
Celule de sarcină de tip forfecare	Q.ty	4
6.4 Capacitate acumulator	Ah	1.1

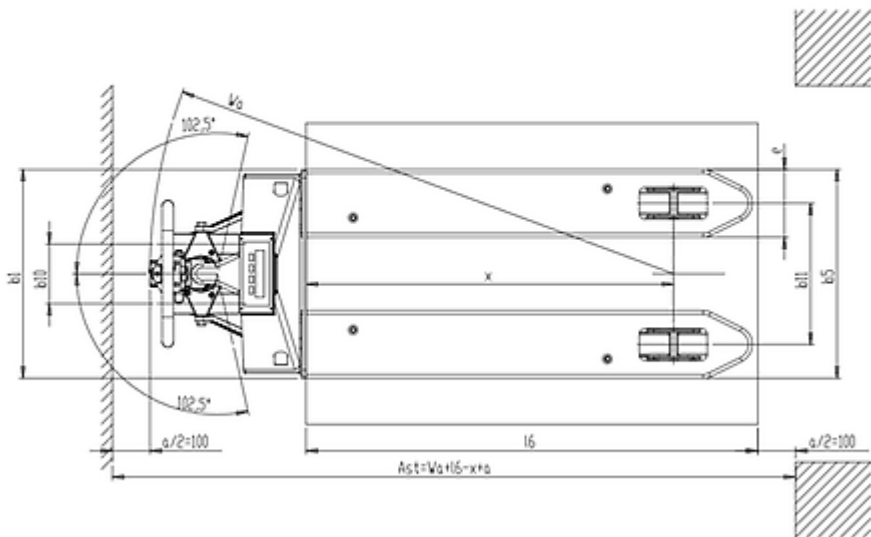
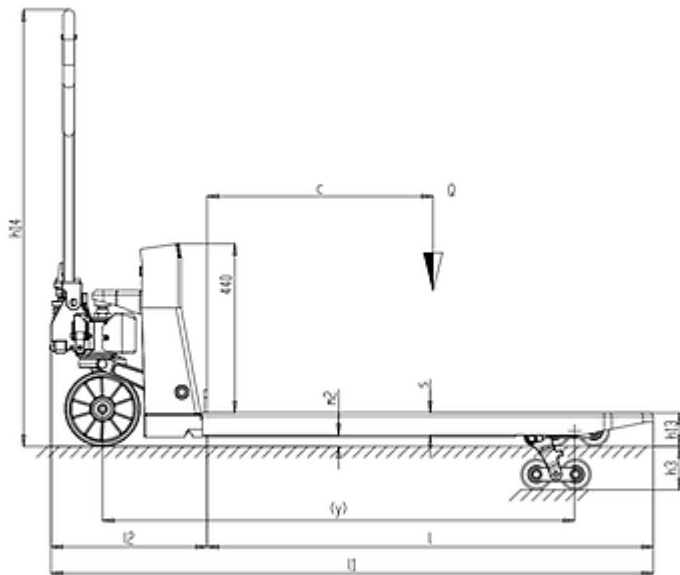

The information is aligned with the Data file at the time of download. Printed on 24/02/2020 (ID 10363)

©2019 | PR INDUSTRIAL s.r.l. | All rights reserved | Image shown may not reflect actual package. Specifications subject to change without notice

